

Voltage Mode Control Using Triangular Wave Slope Modulation for DC-DC Buck Converter

*Shu Wu, Yasunori Kobori, Nobukazu Tsukiji and Haruo Kobayashi (Gunma University)

Abstract—This paper describes a simple-yet-effective control method for a DC-DC buck converter using voltage mode control (VMC), with a triangular wave generator (TWG) which regulates the slope of triangular wave based on the input and output voltages of the converter. Using the proposed TWG, both the load and line transient responses are improved. Since the TWG provides a line feed-forward control for the line transient response, it increases the open-loop bandwidth, and then better dynamic performance is obtained. When the output voltage deviates from the reference signal, the proposed method provides an additional non-linear duty cycle modulation. This non-linear feature provides fast transient response and guarantees system stability. Furthermore this triangular wave slope regulation scheme is simple compared to digital feed-forward control scheme that requires non-linear calculation. Simulation results show the effectiveness of the proposed method.

Key Words: Adjustable Triangular Wave, Voltage Mode Control, Transient Response, Non-linear Control

1 Introduction

Continuous advancement of signal processing technologies for integrated circuits has posed stringent challenges to the design of DC-DC converters. High speed clock and fast dynamic current slew rate for advanced processors make the transient response performance of switching power supply to be more important. When we consider a stable power supply, there are three potential disturbance sources to take into account—the output reference signal, the applied input voltage and the load. Thanks to the well-developed band-gap reference circuit technology and line feed-forward control scheme (only for the buck converter), we do not need worry about the first two disturbance sources. On the other hand, the load transient response is a troublesome issue.

During past twenty years, current mode control (CMC) is considered as a superior approach. Its reasons are not only that CMC has an inherent line feed-forward control, but also that CMC is easy to obtain wideband. A lot of research for the load transient analysis of switching power supplies has indicated that wider band of the control loop can obtain faster load transient response [1-4]. However, the disadvantages of CMC (such as power loss caused by current sensor, additional slope compensation and complicated loop analysis.) give a revival chance to VMC. By now, a VMC converter with the line feed-forward control is not some news [5]. By using Type 3 compensation, the voltage mode control even can obtain comparable dynamic performance. But an expensive wideband amplifier is required. Some research also proposed using feed-forward controller to improve the load transient response. However, load current feed-forward control methods [6, 7] are limited in large load current transient conditions. Digital non-linear control methods have also been proposed [8, 9], but their main drawback is the complexity of non-linear calculation.

This paper proposes a simple control method for VMC buck converters. This approach applies an adjustable TWG, and the slope of this triangular wave is regulated based on the input and output voltages. Therefore, we obtain not only line feed-forward control, but also load transient response improvement, because the open-loop bandwidth is increased by a novel way. And when the output voltage deviates from the reference signal, this approach provides an additional non-linear duty cycle modulation. If the output deviates largely from the reference voltage, the modulation gain becomes large. Conversely, when the output is close to the reference

voltage, the gain becomes small. Therefore, both fast transient response and system stability are guaranteed. The proposed method is simple and does not need any current sensor or complicated calculation.

2 Voltage Mode Control and Type 3 Compensation

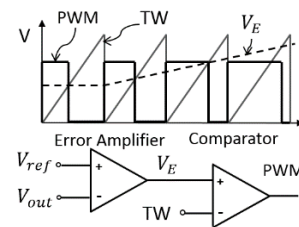

Fig. 1 Duty cycle modulation in VMC.

VMC has a single voltage feedback path, with pulse-width modulation (PWM) performed by comparing the voltage error signal with a constant triangular waveform, as Fig. 1 shown. VMC is easy to design and analyze, and it provides good noise margin. But any change in line or load must be first sensed as an output change and then corrected by the feedback loop; this usually means slow response.

The power stage transfer function for a VMC buck converter is a second-order system. The transfer function from output voltage to the duty cycle is given as:

$$G_{vd} = \frac{V_{in}(1+s/\omega_{ESR})}{1+2\delta(s/\omega_n)+(s/\omega_n)^2} \dots\dots (1)$$

Where ω_{ESR} is the zero point which is caused by the output capacitor ESR, ω_n is the LC double pole, and δ is the damping factor.

Normally, Type 3 compensation (1 zero-pole, 2 poles and 2 zeros) is applied in VMC. The transfer function of Type 3 compensation is given as:

$$G_c = \frac{\omega_1}{s} \cdot \frac{(1+s/\omega_{z1})(1+s/\omega_{z2})}{(1+s/\omega_{p1})(1+s/\omega_{p2})} \dots\dots (2)$$

The simplified gain plots of these Type 3 compensation are shown in Fig. 2. Since the compensation in effect is realized around the error amplifier, the limitation of open-loop gain and gain-bandwidth product of a practical amplifier should be considered. The two zero points— ω_{z1} and ω_{z2} are set both sides of LC poles. Normally, the geometric center of ω_{z2} and ω_{p1} is set as crossover frequency for getting the largest phase compensation. The second pole ω_{p2} is set to eliminate ESR zero. Therefore, in order to obtain wideband, it is required to not only rise the overall compensation gain,

but also push ω_{z2} and ω_{p1} to higher frequencies. However, limited by the gain-bandwidth of the amplifier, an undesired pole type corner appears at ω_{GB} , and the phase should decrease. If this corner frequency is near to the cross-over frequency, the system should be unstable, because there is not enough phase margin. This is the reason why VMC cannot have wideband normally, unless applying an expensive wideband amplifier to implement Type 3 compensation.

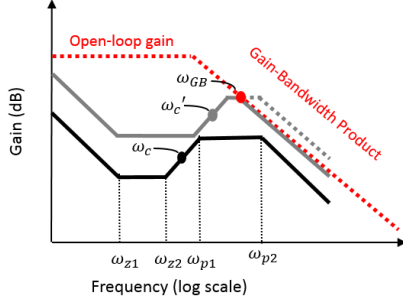

Fig. 2 The Gain Plot of Type 3 Compensation.

3 Slope Adjustable Triangular Wave Generator

This paper proposes a VMC based control scheme. A slope adjustable TWG will be introduced in this section. By this TWG, we build relationship among the triangular wave slope, the input voltage and the output deviation. Therefore, besides the conventional VMC duty cycle modulation, an additional modulation effect caused by the adjustable slope is obtained. The system configuration is shown in Fig. 3.

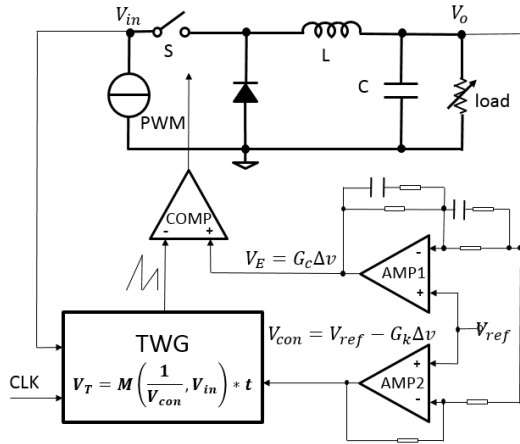

Fig. 3 DC-DC buck converter with a slope adjustable TWG.

Op-amp1 is used to generate an error signal which is compared to the triangular wave, and Type 3 compensation is incorporated. The gain is denoted as G_c . Op-amp2 senses and amplifies the output deviation, and its output works as control variable for the TWG. The gain is denoted as G_k . TWG is a time-variant function of the voltage, and it is reset every period by CLK pulse signal. The slope is decided by the control variable and input voltage; it is proportional to the input voltage, and inversely proportional to the control variable. Therefore, both the line and load transient responses obtain timely regulation.

Fig. 4 shows the principle of the proposed TWG, where two completely consistent NMOSFETs M_1 and M_2 in the triode region are used to configure a linear voltage controlled

resistor (VCR). The difference of two drain voltages is amplified and used to generate a proportional current signal by the voltage controlled current source (VCCS). Then this current signal is copied by the current mirror composed of M_3 and M_4 . The capacitor C_T is charged by this current, and the voltage V_T increases with the slope i_T/C_T , while the clock signal resets V_T every period. Therefore the voltage V_T becomes a triangular wave signal.

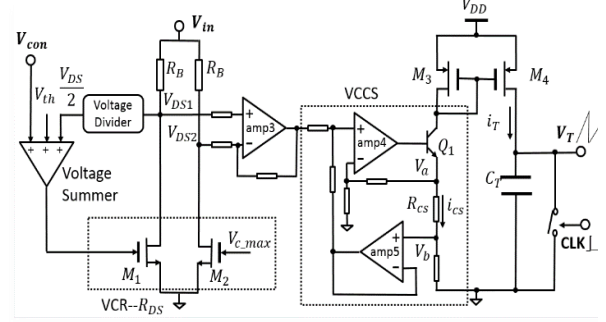

Fig. 4 Proposed triangular wave generator.

Using the sum of the threshold voltage V_{th} , the control variable voltage V_{con} and a half of the drain-to-source voltage $V_{DS}/2$ to drive the gate of a NMOS transistor which works in the triode region, we can obtain a linear resistor controlled by V_{con} . This equivalent resistor can be expressed as:

$$R_{DS} = \frac{1}{K_n V_{con}} \dots \dots (3)$$

Here $K_n = \mu_n C_{ox} W/L$.

The input voltage of the buck converter as another input of the TWG is divided by a resistor R_B and an NMOS equivalent resistance R_{DS} , where R_B is a large resistor. If $R_B \gg R_{DS}$, the drain-to-source voltage V_{DS1} can be approximated as

$$V_{DS1} \approx \frac{R_{DS}}{R_B} V_{in} \dots \dots (4)$$

Substituting eq. (3) into eq. (4), V_{DS1} can be expressed with a function that includes control variable and input voltage:

$$V_{DS1} = \frac{1}{K_n R_B V_{con}} V_{in} \dots \dots (5)$$

Then, V_{DS1} should be used to drive a VCCS. But V_{DS1} and its swing are too small to drive the VCCS. M_2 is the other NMOS that is completely consistent with M_1 . The gate drive voltage V_{GS2} is similar to M_1 , but the control variable is replaced as a constant value and this value is the maximum control variable. With the same R_B , V_{DS2} is given by

$$V_{DS2} = \frac{V_{in}}{K_n R_B V_{con,max}} \dots \dots (6)$$

The difference between these two drain-to-source voltages is amplified by amp3, and its output is given by

$$G_3 \Delta V_{DS} = \frac{G_3 V_{in}}{K_n R_B} \left(\frac{1}{V_{con}} - \frac{1}{V_{con,max}} \right) \dots \dots (7)$$

Here G_3 is the gain of amp3.

In VCCS, amp4 adds $G_3 \Delta V_{DS}$ to V_b and amp5 buffers V_b . Amp4 output current is amplified by Q_1 . The voltage across the resistor R_{CS} is $(V_a - V_b)$. The current through R_{CS} should be expressed as

$$i_{CS} = \frac{G_3 \Delta V_{DS}}{R_{CS}} \dots \dots (8)$$

Current mirror circuit copies this current. Current i_T

charges the capacitor C_T to increase voltage V_T , and the triangular wave can be given as

$$V_T = K \cdot V_{in} \left(\frac{1}{V_{con}} - a \right) t = M \left(V_{in}, \frac{1}{V_{con}} \right) t \dots (9)$$

$$\text{Here } K = \frac{G_3}{K_n R_B R_C S C_T}, \quad a = \frac{1}{V_{con_max}}$$

4 Improvement of Transient Response

4.1 Line Feed-forward Control

For a buck converter with VMC, the transfer function from the error signal to the output can be expressed as

$$V_{out} = \frac{1}{LCs^2 + \frac{L}{R}s + 1} \frac{V_{in}}{V_P} V_E \dots (10)$$

Where L , C and R are output inductor, output capacitor and load resistor, respectively. V_P is the peak value of the triangular wave with the proposed TWG, expressed as

$$V_p = M \left(V_{in}, \frac{1}{V_{con}} \right) T_s \dots (11)$$

Where T_s is switching period. Proportional relationship between the slope and the input voltage forms a feed-forward controller for the line transient response of the buck converter.

4.2 Additional Non-linear Duty Cycle Modulation

If there is step change in the load current, the output voltage should deviate from the reference signal. Then the duty cycle modulation of the buck converter with the proposed TWG should consider the effect of both the error signal and the triangular wave slope, as shown in Fig. 5.

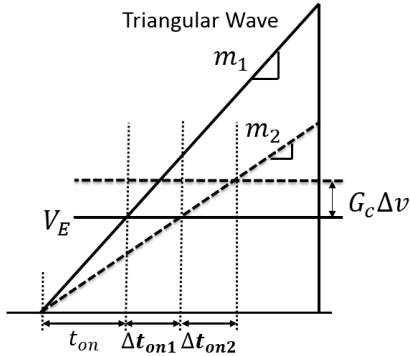

Fig. 5 Duty cycle modulation by proposed TWG

m_1 and m_2 are the original slope and the one regulated by the variation in output, respectively. V_E is the static operation point of the error signal. $G_c \Delta v$ means the error signal variation caused by the output voltage deviation from the reference signal. We see in Fig.5 that the duty cycle variation is separated into two part--- $\Delta d_1 = \Delta t_{on1}/T_s$ and $\Delta d_2 = \Delta t_{on2}/T_s$. Δd_1 is the variation which only depends on the slope variation, expressed as

$$\Delta d_1 = \frac{V_E}{T_s} \left(\frac{1}{m_2} - \frac{1}{m_1} \right) = \frac{V_E}{T_s} \Delta \frac{1}{m} \dots (12)$$

Δd_2 is the duty cycle variation caused by the error signal and the slope, expressed as

$$\Delta d_2 = \frac{G_c \Delta v}{T_s} \left(\frac{1}{m_1} + \Delta \frac{1}{m} \right) = \frac{G_c \Delta v}{T_s m_1} + \frac{G_c \Delta v}{T_s} \Delta \frac{1}{m} \dots (13)$$

Then the whole duty cycle modulation is obtained as:

$$\Delta d = \Delta d_1 + \Delta d_2 = \frac{V_E + G_c \Delta v}{T_s} \Delta \frac{1}{m} + \frac{G_c \Delta v}{T_s m_1} \dots (14)$$

In eq. (14), $T_s m_1 = V_{p_static}$ is the static operation point of the triangular wave peak voltage. Therefore, the second term is the duty cycle modulation in a conventional VMC buck converter, while the first term is an additional modulation. According the description about the triangular wave slope in eq. (9), the first term in eq. (14) is given as:

$$\frac{V_E + G_c \Delta v}{T_s} \Delta \frac{1}{m} = A(\Delta v) \Delta v \dots (15)$$

$$\text{Where } A(\Delta v) = \frac{(V_E + G_c \Delta v) G_k}{K V_{in} T_s (1 - a V_{ref} - a G_k \Delta v) (1 - a V_{ref})}$$

The duty cycle modulation can be rewrote as:

$$\Delta d = \left(A(\Delta v) + \frac{G_c}{T_s m_1} \right) \Delta v \dots (16)$$

Since $A(\Delta v)$ non-linearly follows the output deviation, the proposed control scheme shows a non-linear control features, as followings:

- (1) If the output voltage deviates largely from the reference voltage, the modulation gain becomes large, which enables fast transient response.
- (2) If the output voltage is close to the reference voltage, the modulation gain becomes small, and approaches to a constant value, which is desirable for the loop stability.

4.3 Wideband and Stability Analysis

Now we analyze the system stability, and suppose that Δv is small enough. Then $A(\Delta v)$ approaches to a constant value:

$$A = \frac{V_E G_k}{K V_{in} T_s (1 - a V_{ref})^2} \dots (17)$$

According to eqs. (11) and (16), the system can be described as the block diagram as shown in Fig. 6.

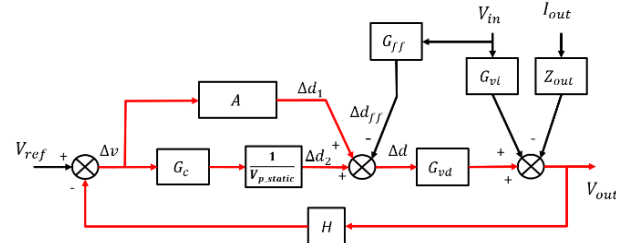

Fig. 6 System block diagram

The system feedback loop transfer function can be written as

$$T = \left(A + \frac{G_c}{V_{p_static}} \right) G_{vd} H \dots (18)$$

Table.1 Parameters and phase compensation

Buck Converter Parameter	$V_{in} = 5V, V_{out} = 3.5V, V_{p_static} = 3V$ $L = 10\mu H (ESR: r_L = 10m\Omega),$ $C = 50\mu F (ESR: r_C = 10m\Omega), R = 35\Omega$ $f_{switch} = 1MHz, H = 1$
Phase Compensation Goal	$f_c = 1/20 f_{switch} = 50kHz$ $PM = 40^\circ$

A practical DC-DC buck converter as an example is used to help us analyze the stability, and the simulation in next section also is based on this example. The buck converter

parameters and Type 3 compensation design goal are shown in Table.1.

According the parameters of the buck converter, we can set $A \approx 30$. The open-loop of the feedback system can be separated into two parts $--G_c G_{vd}/V_{P_static}$ and AG_{vd} . The Bode plot is shown in Fig.7. f'_c is the crossover frequency of the conventional feedback system, which is equal to 50kHz. While f_c is the crossover frequency of the feedback system with the proposed TWG, it is near 109kHz. The open-loop bandwidth of is increased. However, the phase margin is sacrificed and decreased to only 10° .

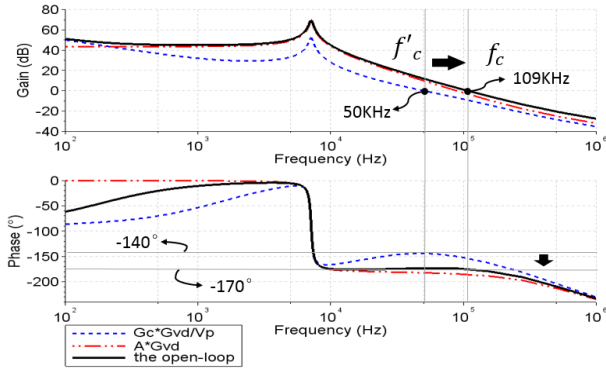

Fig.7 Bode plot of the feedback system with the proposed TWG

Nyquist plot more clearly shows the effect of the proposed approach to a conventional feedback system. Fig.8 shows Nyquist plot of the open-loop and its two components, only considering the part from cross frequency of the conventional system (50kHz) to the switching frequency (1MHz).

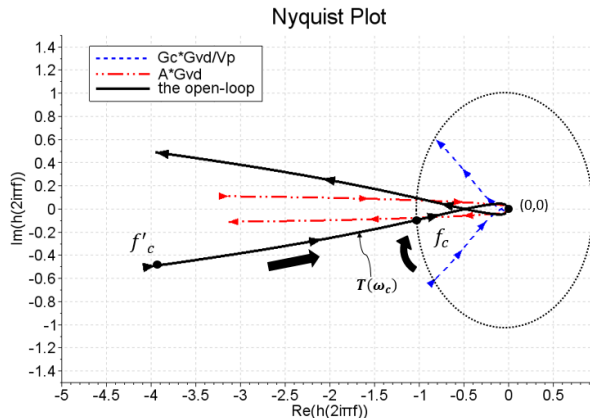

Fig.8 Nyquist plot of the open-loop (@ $A=30$ and the original system $PM=40^\circ f'_c = 50kHz$)

We can see from the Nyquist plot that in order to obtain enough phase margin, we can increase the phase of G_c and/or A . However, due to the gain-bandwidth limitation of op-amp, obviously increasing the phase of G_c at high frequency range is a risky behavior. Therefore, the gain-- A is the only chance. Both amp2 in Fig. 3 and amp3 in Fig.4 can be chosen to set a zero point at desired cross frequency. Additional high frequency zero point will increase the phase of AG_{vd} , and then, the phase of the whole system also be increased, and enough phase margin is obtained. Bode plot comparison between with and without this simple additional phase compensation is shown in Fig.9; we see that phase margin is increased from 10° to 30° , and the bandwidth also

be increased a little.

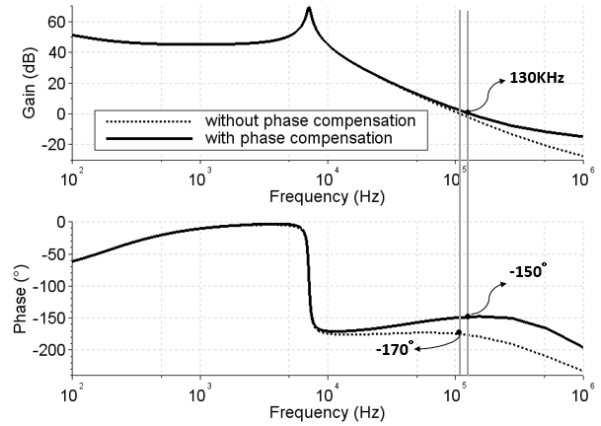

Fig.9 Bode plots of the system with and without additional phase compensation.

Notice that whether the increasing of bandwidth or the additional phase compensation does not need modify the amp1 which is used to realize Type 3 compensation. Therefore, we do not need worry about that the gain-bandwidth limitation would affect the system stability as conventional VMC.

5 Simulation Result

The DC-DC buck converter mentioned in the previous section is used as SIMetrix simulation object and its line and load transient responses are investigated. The simulation results will be compared to the conventional VMC buck converter to prove the effectiveness of the proposed TWG.

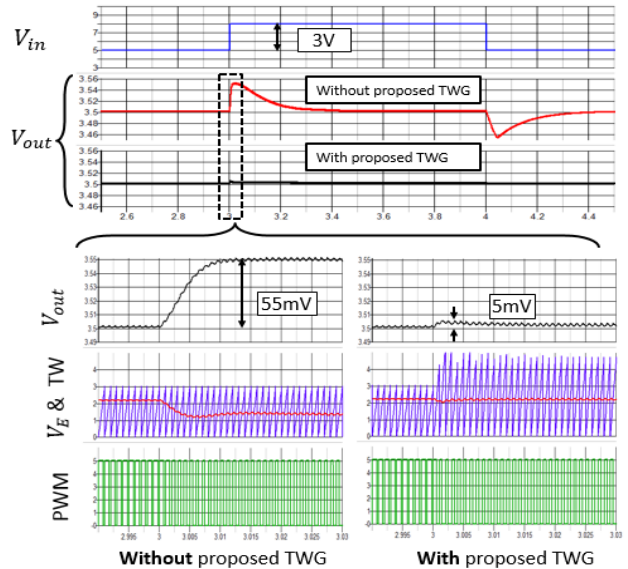

Fig.10 Line transient response ($V_{in}: 5V \leftrightarrow 8V$)

First, consider line transient response. If the input voltage is changed stepwise from 5V to 8V, the simulation result and the comparison with convention VMC are as shown in Fig.10. Since the slope of triangular wave is regulated to follow the input voltage, the adjustable triangular wave and the error signal generate a timely and suitable PWM signal for the converter. In other words, the effect of the changed input voltage is eliminated by feed-forward control.

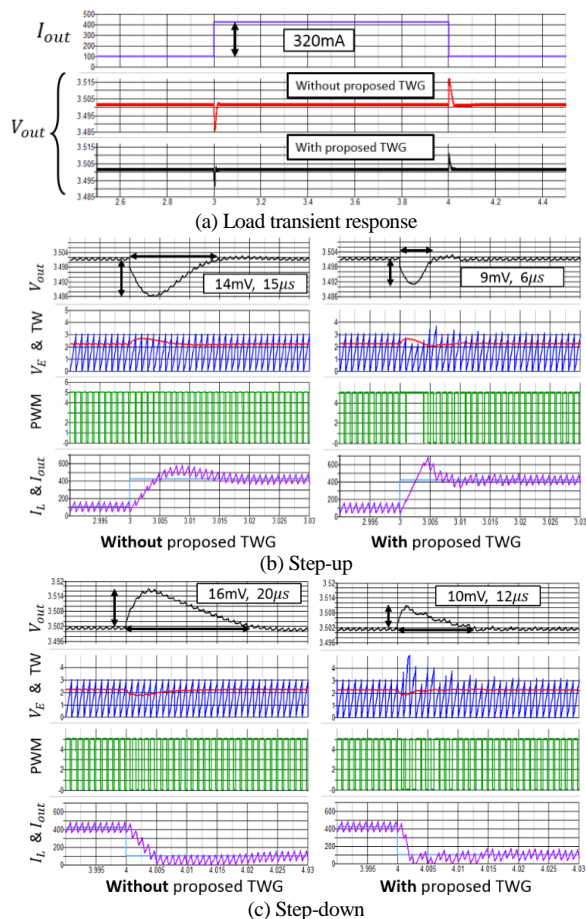

Fig. 11 Load transient responses ($I_{out}: 100mA \leftrightarrow 420mA$).

In load transient response simulations, the load current is changed stepwise between 100mA and 420mA and still compare to the conventional VMC buck converter. The simulation result is shown in Fig. 11.

We see from the simulation results that because of the slope adjustable triangular wave, the duty cycle is regulated as soon as the transient response happens. Comparing to conventional VMC, the additional duty cycle modulation provided by the proposed TWG prevents larger error signal development. Therefore, the over-shoot and under-shoot voltages are decreased and the response time is shortened. In step-up case, the under-shoot voltage is decreased from 14mV to 9mV, and the response time is shortened from 15 μ s to 6 μ s. In step-down case, the over-shoot voltage and response time of the system only with conventional VMC are 16mV and 20 μ s, respectively. While these two specifications of the system with the proposed adjustable TWG are improved as 10mV and 12 μ s. The peak-to-peak voltage is only 19mV, smaller than 1% of output voltage.

6 Conclusion

This paper describes a novel control scheme which uses a slope adjustable triangular wave generator to improve the transient response of buck converter with VMC. The proposed method is very simple, and it does not need a current sensor, digital signal processing or complicated calculation. Compared to the conventional VMC, the proposed method

improves both the line and load transient responses. For the line transient response, it works as a feed-forward controller to eliminate the change in input voltage. For the load transient response, the proposed method provides an additional non-linear duty cycle modulation, besides the effect of the error signal. Our stability analysis shows that the open-loop bandwidth is increased by the proposed triangular wave generator, but the phase margin is sacrificed. However, with a sample phase compensation, the proposed system can be stable with better dynamic performance. Wideband and enough phase margin are obtained without modifying the configuration of Type 3 compensation, therefore the system is not easily affected by the gain-bandwidth product of the op-amp. Our simulation results show that the line and load transient responses are improved with the proposed method.

References

- 1) P. Wong, F. C. Lee, X. Zhou, and J. Chen, "VRM transient study and output filter design for future processors," Proc. IEEE IECON, vol.1, pp.410–415, Aachen, Germany, Aug.-Sep.1998.
- 2) B. Arbetter and D. Maksimovic, "DC-DC converter with fast transient response and high efficiency for low-voltage microprocessor loads," Proc. IEEE APEC 1998, vol.1, pp.156–162, Anaheim, CA, Feb. 1998
- 3) C. J. Mehas, K. D. Coonley, and C. R. Sullivan, "Converter and inductor design for fast-response microprocessor power delivery," Proc. IEEE PESC, vol.3, pp. 1621–1626, Galway, Ireland, Jun. 2000.
- 4) J. Xu, X. Cao, and Q. Luo, "The effects of control techniques on the transient response of switching DC-DC converters," Proc. IEEE PEDS, vol.2, pp. 794–796, Hong Kong, China, Jul. 1999.
- 5) B. Arbetter, D. Maksimovic, "Feed-forward pulse-width modulators for switching power converters," 26th Annual IEEE, PESC'95, vol.1, pp. 601-607, Atlanta, GA, Jun. 1995.
- 6) M. Karppanen, M. Hankaniemi, T. Suntio, and M. Sippola, "Dynamical characterization of peak-current-mode controlled buck converter with output-current feed-forward," IEEE Trans. Power Electronics, vol. 22, no.2, pp. 444-451, Mar. 2007.
- 7) A. V. Peterchev, and S. R. Sanders, "Load-line regulation with estimated load-current feed-forward application to microprocessor voltage regulators," IEEE Trans. Power Electronics, vol. 21, no.6, pp. 1704-1717, Nov. 2006.
- 8) V. Yousefzadeh, A. Babazadeh, B. Ramachandran, L. Pao, D. Maksimovic, and E. Alarcon, "Proximate time-optimal digital control for DC-DC converters," Proc. IEEE, PESC, pp. 124-130, Orlando, FL, Jun. 2007.
- 9) S.Y. Chae, B.C. Hyun, W.S. Kim, and B.H. Cho, "Digital load current feed-forward control method for a DC-DC converter," Proc. IEEE APEC, pp. 498-502, Austin, TX, Feb. 2008.