

## **Derivation of Loop Gain and Phase from Output Impedances in Analog Circuit with Negative Feedback**

Nobukazu Tsukiji<sup>a</sup>, Yasunori Kobori<sup>b</sup> and Haruo Kobayashi<sup>c</sup>

Division of Electronics and Informatics, Gunma University, 1-5-1, Tenjin-cho Kiryu, Gunma 376-8515, Japan

<sup>a</sup><ntsukiji@gunma-u.ac.jp>, <sup>b</sup><kobori@gunma-u.ac.jp>, <sup>c</sup><koba@gunma-u.ac.jp>

**Keywords:** Loop gain measurement, Stability evaluation, Stability of negative feedback system, Phase margin, Dc-dc buck converter.

**Abstract.** We propose a method to derive the loop gain and phase from the output impedances in analog circuit with negative feedback. In this paper, we apply the proposed method to the dc-dc buck converter as a target of the analog circuit with negative feedback. This enables to measure the loop gain without injecting a signal into feedback loop, i.e. without breaking the feedback loop; hence the proposed method can be applied for the control circuits implemented on an IC. Our simulation and experiment results show that the loop gain obtained from the proposed method matches very well with the one from the conventional method.

### **1. Introduction**

Measurement of the loop gain is important to evaluate the stability of the negative feedback system. In general, loop gains can be experimentally measured by use of voltage injection [1-8]. This approach ensures correct quiescent operating conditions in the system, and avoids a common difficulty in systems having a large dc loop gain. However, in principle, this method needs to inject a voltage signal into the feedback loop with breaking a measurement point in the feedback loop. In addition, an injection point has some restrictions.

In this paper we propose a method to obtain the loop gain and phase from the converter output impedances. We apply the proposed method to the dc-dc buck converter as a target of the analog circuit with negative feedback. This method does not need to inject a voltage signal into a feedback loop. We show the details of the proposed method with its simulation and experimental results.

### **2. Conventional Method to Obtain Loop Gain**

Let us consider the measurement of the loop gain  $T$  of the feedback system of Fig. 1. There the output port of block 1 is represented by a Thevenin-equivalent network, composed of the voltage-controlled voltage source and output impedance. Block 1 is loaded by the input impedance of block 2. To measure the loop gain by voltage injection, we connect a network analyzer to measure the transfer function  $\Delta V_x$  from  $\Delta V_y$ . The system independent ac inputs are set to zero, and the network analyzer sweeps the injection voltage  $\Delta V_z$  over the intended frequency range. The measured gain is given by

$$T_v \equiv \left. \frac{\Delta V_y}{\Delta V_x} \right|_{\Delta V_{ref}=0, \Delta V_{in}=0} \quad (1)$$

Solution of Fig. 1 for the measured gain  $T_v$  is obtained as follows [1,2]:

$$T_v = T \left( 1 + \frac{Z_1}{Z_2} \right) + \frac{Z_1}{Z_2} \quad (2)$$

Thus,  $T_v$  can be expressed as the sum of two terms. The first term is proportional to the actual loop  $T$ , and is approximately equal to  $T$  in case  $|Z_1/Z_2| \ll 1$ . The second term is not proportional to  $T$ ,

and limits the minimum  $T$  that can be measured with the voltage injection technique. If  $Z_1/Z_2$  is much smaller in magnitude than  $T$ , then the second term can be ignored, and  $T_v \approx T$ . At frequencies where  $T$  is smaller in magnitude than  $Z_1/Z_2$  the measured data must be discarded.

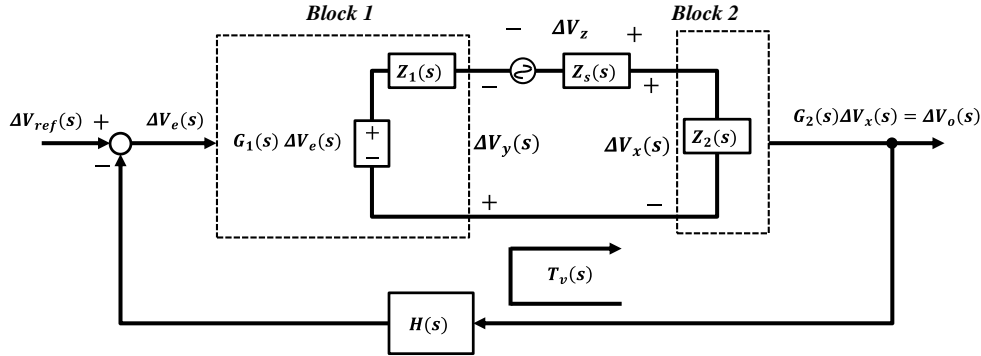

Fig. 1. Measurement of loop gain by voltage injection [1,2].

### 3. Derivation of Proposed Method

Figure 2 shows a feedback loop for regulation of the output voltage in dc-dc buck converter. In the open-loop condition, the converter power stage contains three independent inputs: the control input variations  $\Delta D$ , the power input voltage variations  $\Delta V_{in}$ , and the load current variations  $\Delta I_o$ . Hence the output voltage variation  $\Delta V_o$  can be expressed as a linear combination of the three independent inputs, as follows:

$$\Delta V_o = G_{vd}\Delta D + G_{vi}\Delta V_{in} - Z_o\Delta I_o \quad (3)$$

where  $G_{vd}$  is converter control-to-output transfer function,  $G_{vi}$  is converter line-to-output transfer function and  $Z_o$  is converter output impedance. When  $\Delta D = 0$  and  $\Delta V_{in} = 0$ , the converter output impedance  $Z_o$  in the open loop is defined as

$$Z_o \equiv \left. \frac{\Delta V_o}{-\Delta I_o} \right]_{\Delta D=0, \Delta V_{in}=0} \quad (4)$$

In the closed loop condition, solution of Fig. 2 (b) for the output voltage variation  $\Delta V_o$  is given as follows:

$$\Delta V_o = \frac{1}{H} \frac{T}{1+T} \Delta V_{ref} + \frac{G_{vi}}{1+T} \Delta V_{in} - \frac{Z_o}{1+T} \Delta I_o \quad (5)$$

When  $\Delta V_{ref} = 0$  and  $\Delta V_{in} = 0$ , the converter output impedance  $Z_{oc}$  in the closed loop is defined as

$$Z_{oc} \equiv \left. \frac{\Delta V_o}{-\Delta I_o} \right]_{\Delta V_{ref}=0, \Delta V_{in}=0} = \frac{Z_o}{1+T} \quad (6)$$

We consider that based on Eq. (6), the loop gain  $T$  can be derived from both the output impedances; the loop gain and phase are obtained as Eqs. (7) and (8).

$$20 \log_{10}|T| = 20 \log_{10} \left( \frac{|Z_o - Z_{oc}|}{|Z_{oc}|} \right) \quad (7)$$

$$\arg(T) = \arg(Z_o - Z_{oc}) - \arg(Z_{oc}) \quad (8)$$

This method does not to inject a voltage signal into the feedback loop to obtain the loop gain.

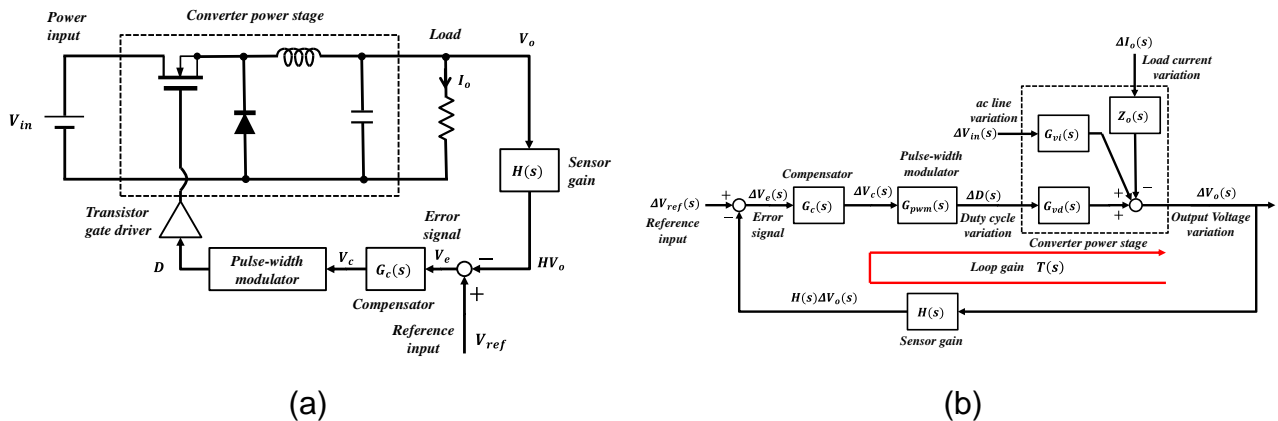

Fig. 2. Feedback loop for regulation of the output voltage in dc-dc buck converter. (a) Feedback loop block diagram. (b) Functional block diagram of the feedback system [2].

#### 4. Simulation Result

We have conducted simulation using SIMPLIS simulator by SIMetrix Technologies Ltd. This simulator can run the AC analysis not to lead the average model for the dc-dc converter of a complete switching non-linear time domain model. Fig. 3 (a) shows the simulation circuit of measuring the loop gain by conventional method. Fig. 3 (b) shows the simulation circuit of measuring the both of the output impedance  $Z_o$  and  $Z_{oc}$ . When measuring  $Z_o$ , it is necessary to hold a constant output voltage of the error amplifier by turning on the SW in Fig. 3 (b). Figure 4 shows the simulation result of  $Z_o$  and  $Z_{oc}$  with the configuration in Fig. 3 (b). From the results of Fig. 4 (a) and (b), we derive the loop gain by calculation using Eqs. (7) and (8). These results are shown in Fig. 5. The solid line is derived by the conventional method and the plot in the square is derived by the proposed method. We see that these results exactly match.

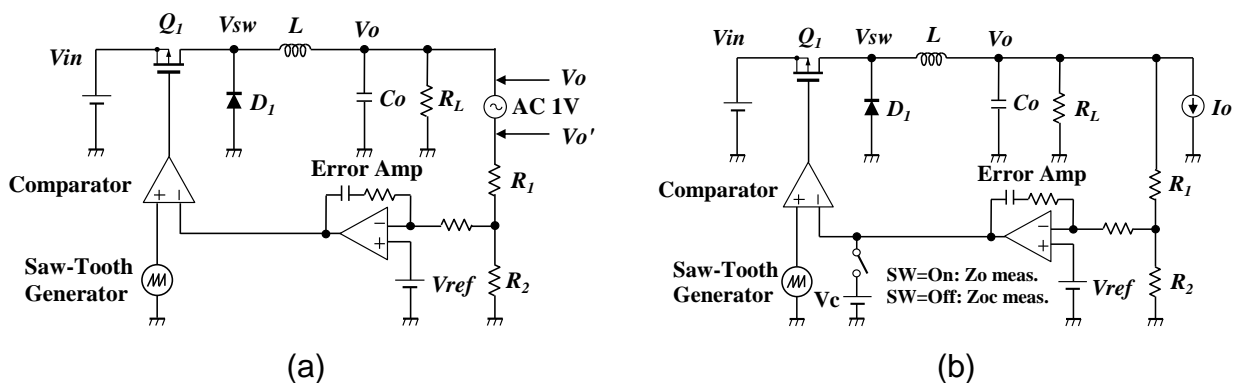

Fig. 3. Simulation circuit for measuring the loop gain. (a) Conventional loop gain measurement circuit. (b)  $Z_o$  and  $Z_{oc}$  measurement circuit.

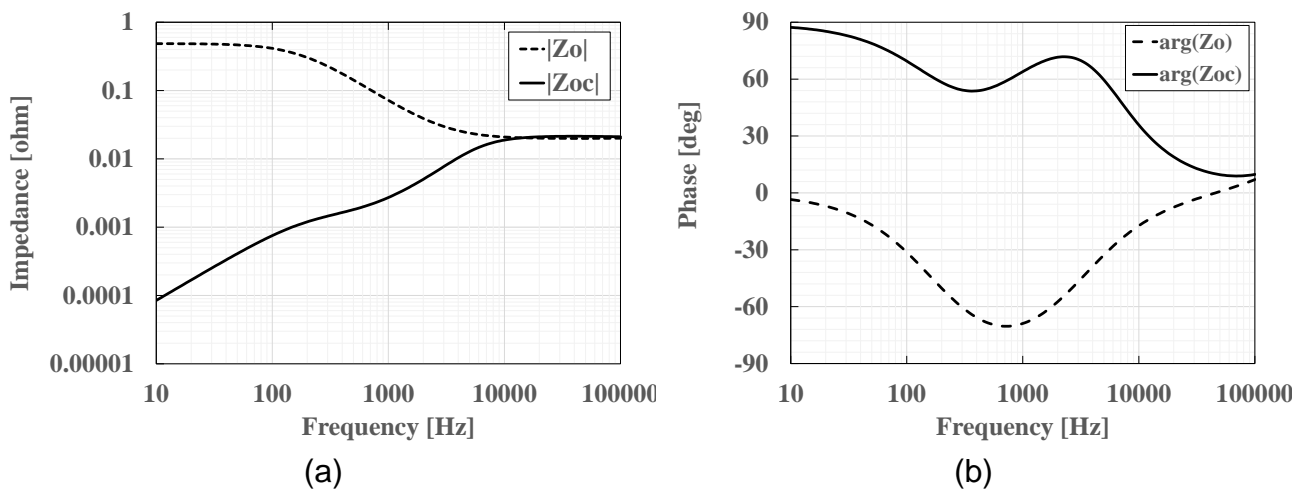

Fig. 4. Simulation result of  $Z_o$  and  $Z_{oc}$  in Fig. 3 (b). (a) Impedance. (b) Phase.

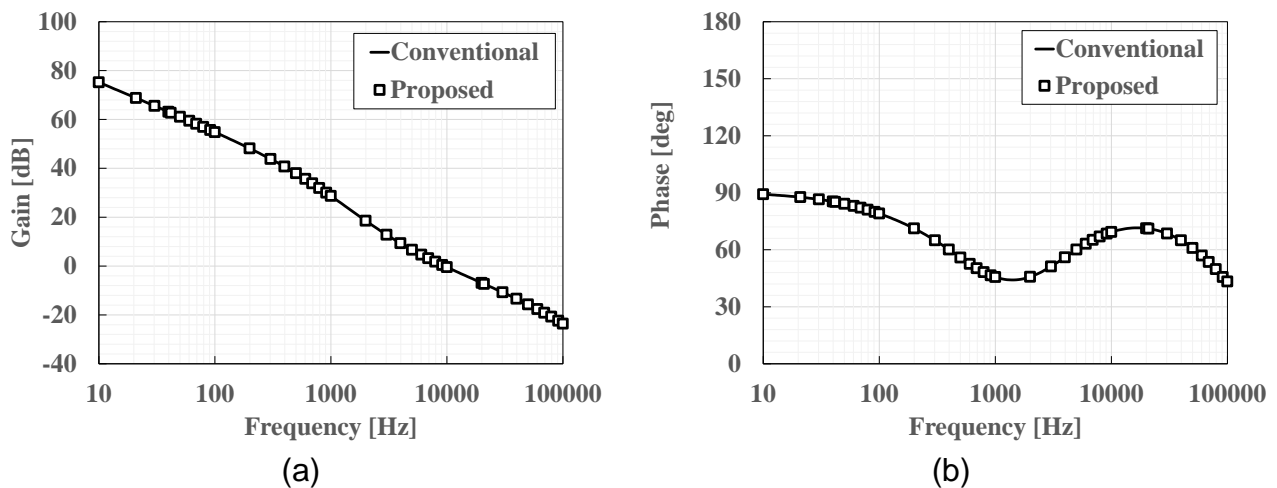

Fig. 5. Comparison of loop gain in Fig. 3. (a) Gain. (b) Phase.

## 5. Experimental Result

We show experimental results of applying the proposed method to a dc-dc buck converter. The converter used in the experiment is a non-isolated type with current mode control and switching frequency of 380 kHz. Experimental conditions are the following; input voltage of 12V, output voltage of 3.3V, output load of 1A. When measuring  $Z_o$ , it is connected to an external power source in order to hold the output of the error amplifier and the voltage of the external power source is adjusted so that the output voltage is 3.3V. We measure the output impedance using the Frequency Response Analyzer (FRA) by NF Corporation.

Figure 6 shows comparison of the loop gains obtained in the experiment. The solid line is the one derived by the conventional method and the dotted line is the one by the proposed method. In the proposed method, the measured result does not have good accuracy at low frequencies. This is because in the low-frequency range, the output impedance in a closed loop is extremely small, and there S / N ratio of the measurement signal is poor. However, in the range from 1 kHz to 100 kHz, we see that the conventional method and the proposed method have good agreements, and we consider from these results that sufficient evaluation of the phase margin and gain margin is feasible with the proposed method.

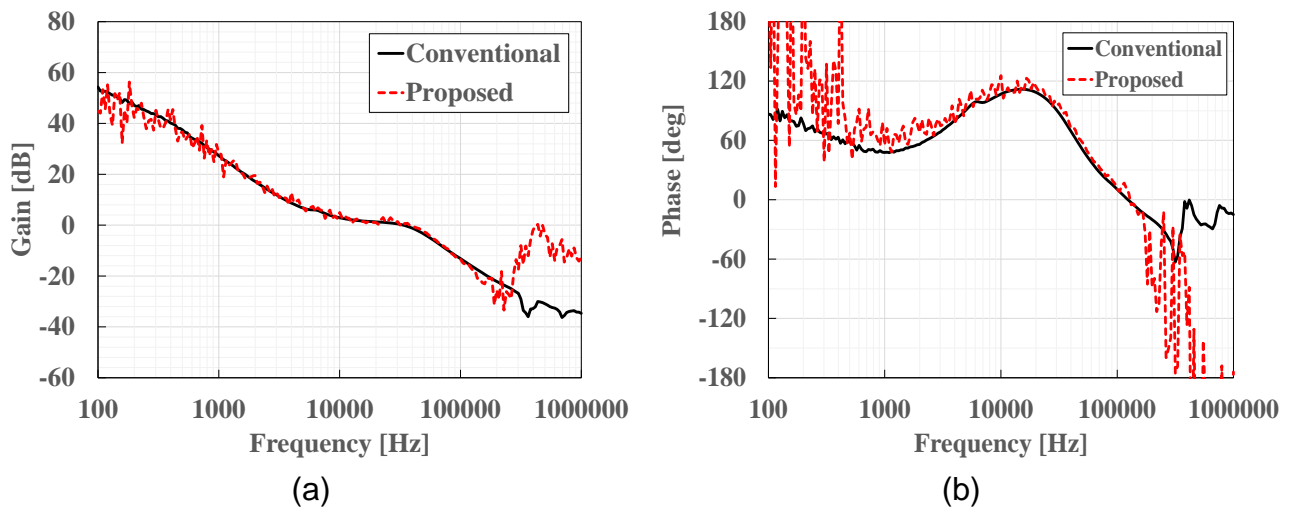

Fig. 6. Comparison of loop gain in experiment. (a) Gain. (b) Phase.

## 6. Summary

We have proposed a method to derive the loop gain and phase from the output impedances in dc-dc buck converter. Our simulation results showed that the loop gain obtained from the proposed method exactly matches with the one from the conventional method. Furthermore, we showed the experimental results of applying the proposed method to a dc-dc buck converter, and we found out that sufficient evaluation of the phase margin and gain margin is possible with the proposed method.

Conventional loop gain measurement method needs to inject a voltage signal into the feedback loop, and hence breaking a part of the feedback loop is necessary; this cannot be used when the feedback loop is implemented on an IC. On the other hand, the proposed method does not need to inject a signal into the feedback loop, and it is expected to use widely in the feedback circuit measurement.

## References

- [1] R. D. Middlebrook, "Measurement of Loop Gain in Feedback Systems," *International Journal of Electronics*, vol. 38, no. 4, pp. 485-512, 1975.
- [2] R. W. Erickson, D. Maksimovic, *Fundamentals of Power Electronics*, 2nd Edition, Springer, NY, 2001.
- [4] R. B. Ridley, "Frequency Response Measurements for Switching Power Supplies," Texas Instruments, Application Note SLUP121, 2001.
- [5] R. B. Ridley, "Measuring Frequency Response: Tips and Methods," *Switching Power Magazine*, vol.3, issue 2, pp.12-27, 2002.
- [6] Y. Panov and M. M. Jovanovic, "Small-Signal Measurement Techniques in Switching Power Supplies," *2004 IEEE Applied Power Electronics Conference and Exposition (APEC)*, pp. 770-776 vol.2, 2004.
- [7] C. P. Basso, *Designing Control Loops for Linear and Switching Power Supplies: A Tutorial Guide*, Artech House, 2012.
- [8] H. Kobayashi, T. Nabeshima (Editors), *Handbook of Power Management Circuits*, Pan Stanford Publishers, Singapore, 2016.